



Progressive Recovery, Inc.



MODEL SC Distillation Units

Model SC distillation units are ideal for the small to medium size solvent user with throughput rates up to 20.8 gallons per hour*.

MAXIMIZE SOLVENT RECOVERY

- Cut virgin solvent purchase volumes
- Reclamation rates as much as 90%*
- Units typically pay for themselves in a matter of months- see sample ROI chart for reference

IMPROVED SUSTAINABILITY

- Avoid large quantity waste generator status
- Reduce the risks of handling and storing large numbers of hazardous waste drums
- Reduce the size of your facility's environmental footprint

DURABLE, SAFE CONSTRUCTION

- Industry Exclusive 10 Year Limited Warranty on the Boiling Vessel
- Removable low watt density heaters in oil jacket for longer life
 - Outlive systems with high watt density heaters
 - Designed for severe service
- Heat transfer takes place through the bottom and sides, allowing for greater efficiency than other brands which only heat the bottom of the boiling vessel
- Full diameter lids for inspection and cleaning
 - Built with the operator in mind
- Valve to discharge waste into bucket or drum
 - Allows safe and efficient handling of liquid waste
- Stainless steel construction for all wetted surfaces
 - Improved chemical resistance over carbon steel
- Spiral wound condensers for high cooling efficiency
- Vapor and oil temperature sensors
 - Redundant safeties to prevent over temperature
- Options available, including vacuum systems and bag liners



(Model SC-50 on optional elevated base)

SAMPLE RETURN ON INVESTMENT*

DESCRIPTION:	PRI Recovery	No Recovery
Solvent Type: Various		
Waste Generated (gal/wk)	275	275
Percent Solids	5%	5%
Recovered Solvent (gal/wk)	248	0
Required Makeup (gal/wk)	14	261
Disposal Amount (gal/wk)	27	275
Weekly Service Recovery & Disposal Cost	N/A	N/A
Utility Operating Cost/Week	\$17	\$0
Replacement Solvent Cost/Gal	\$5	\$5
Required Makeup Cost/Week	\$69	\$1,306
Disposal Cost/Gal	\$1	\$1
Disposal Cost/Week	\$27	\$275
Total Cost/Week	\$113	\$1,581
Equipment Acquisition Cost	\$30,000	N/A
Weekly Savings w/PRI	\$1,469	
Yearly Savings w/PRI	\$73,425	
Months to Payback	5	
Return On Investment	245%	

* Depends upon type of solvent, contamination level, contaminate type and other factors.



Progressive Recovery, Inc.

MODEL SC

Distillation Units

MODEL	CAPACITY	RATE*	HEATER	A	B	C	WEIGHT
SC-25	57 L (15 G)	11 L/h (2.8 G/h)	3.75 kw	1524 mm (5')	1092 mm (3' 7")	1016 mm (3' 4")	318 kg (700 lbs)
SC-50	121 L (32 G)	18 L/h (4.8 G/h)	7.5 kw	1524 mm (5')	1321 mm (4' 2")	1219 mm (4')	454 kg (1000 lbs)
SC-100	121 L (32 G)	30 L/h (7.8 G/h)	9.0 kw	1524 mm (5')	1321 mm (4' 2")	1219 mm (4')	454 kg (1000 lbs)
SC-155	235 L (62 G)	34 L/h (9 G/h)	9.0 kw	1626 mm (5' 4")	1524 mm (5')	1524 mm (5')	499 kg (1100 lbs)
SC-200	235 L (62 G)	55 L/h (14.4 G/h)	18.0 kw	1626 mm (5' 4")	1524 mm (5')	1524 mm (5')	499 kg (1100 lbs)
SC-300	386 L (102 G)	79 L/h (20.8 G/h)	27.0 kw	1829 mm (6')	1524 mm (5')	1524 mm (5')	590 kg (1300 lbs)

* "Defined Rate" is defined as 2000 BTU/gal. solvent being distilled at 100 deg. differential between the solvent and the heating media.
Custom sizes available upon request.

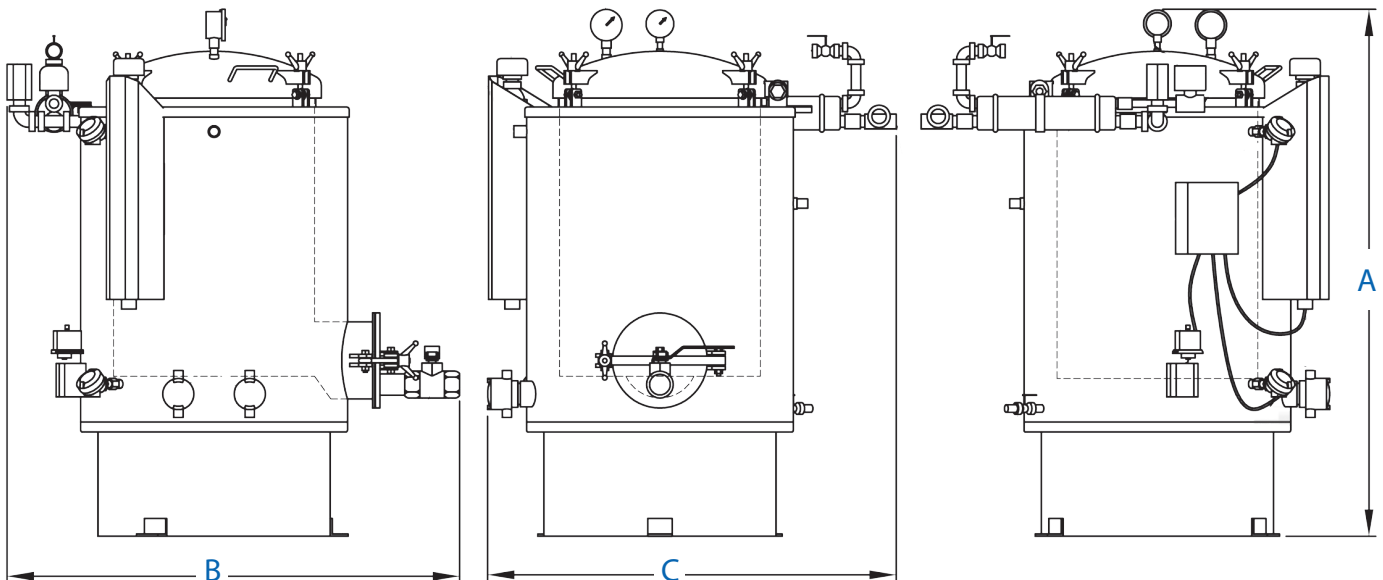

Solvent Wash & Recovery | Biowaste Sterilization | Custom Process Skids | Service

700 Industrial Drive, Dupon IL 62239, (800) 732-3793, www.progressive-recovery.com

SC-Distillation-Spec-20170309