



Progressive Recovery, Inc.



MODEL SCR Distillation Units

Model SCR distillation units are designed for dirty solvent waste streams with up to 20% solids loading throughput rates up to 115 gallons per hour.* The SCR series use PRI's exclusive rotating scraper blade assembly to insure optimum throughput efficiency and minimal maintenance.

MAXIMIZE SOLVENT RECOVERY

- Cut virgin solvent purchase volumes
- Reclamation rates as much as 90%*
- Reduce hazardous waste disposal volume
- Units typically pay for themselves in a matter of months.

REDUCED ENVIRONMENTAL IMPACT

- Reduce the risks of handling and storing large numbers of hazardous waste drums.
- Reduce the size of plant's environmental footprint

DURABLE, SAFE CONSTRUCTION

- Industry Exclusive 10 Year Limited Warranty on the Boiling Vessel
- ASME stamped boiling vessels standard
- Available as steam heated or electrically heated systems
- Scraper blade assembly cleans heat transfer surface of sludge buildup for high the high distillation efficiency.
- PLC control of all operating functions and processes
- Frees operator for other duties.
- Electrically heated have removable low watt density heaters in an oil jacket for longer life.
- Outlive systems with high watt density heaters
- Designed for severe service
- Conical bottom with air operated dump valve to discharge sludge into drum.
- Allows safe and efficient handing of liquid sludge
- Heat transfer takes place through the bottom and sides for higher rates.
- Greater efficiency than systems that only heat the bottom of the boiling vessel.



(Model SCR-200E)

SAMPLE RETURN ON INVESTMENT*

DESCRIPTION:	PRI Recovery	No Recovery
Solvent Type: Various		
Waste Generated (gal/wk)	1,115	1,115
Percent Solids	5%	5%
Recovered Solvent (gal/wk)	1004	0
Required Makeup (gal/wk)	56	1,059
Disposal Amount (gal/wk)	111	1,115
Weekly Service Recovery & Disposal Cost	N/A	N/A
Utility Operating Cost/Week	\$67	\$0
Replacement Solvent Cost/Gal	\$5	\$5
Required Makeup Cost/Week	\$279	\$5,296
Disposal Cost/Gal	\$1	\$1
Disposal Cost/Week	\$111	\$1,115
Total Cost/Week	\$457	\$6,411
Total Yearly Cost	\$22,857	\$320,563
Equipment Acquisition Cost	\$81,000	N/A
Weekly Savings w/PRI	\$5,954	
Yearly Savings w/PRI	\$297,705	
Months to Payback	3	
Return On Investment	368%	

* Depends upon type of solvent, contamination level, contaminate type and other factors.



Progressive Recovery, Inc.

MODEL SCR Distillation Units

MODEL	CAPACITY	RATE*	HEATER	A	B	C	WEIGHT
SCR-200	280 L (74 G)	76 L/h (20 G/h)	Electric or Steam	3150 mm (10' 4")	1600 mm (5' 3")	1651 mm (5' 5")	1361 kg (3,000 lbs)
SCR-250	450 L (119 G)	106 L/h (28 G/h)		3378 mm (11' 1")	1600 mm (5' 3")	1651 mm (5' 5")	1451 kg (3,200 lbs)
SCR-350	768 L (203 G)	161 L/h (42.5 G/h)		3454 mm (11' 4")	1854 mm (6' 1")	2007 mm (6' 7")	2268 kg (5,000 lbs)
SCR-400	1192 L (315 G)	225 L/h (59.4 G/h)		4089 mm (13' 5")	2083 mm (6' 10")	2184 mm (7' 2")	2585 kg (5,700 lbs)
SCR-450	1627 L (430 G)	284 L/h (75 G/h)		4394 mm (14' 5")	2083 mm (6' 10")	2235 mm (7' 4")	2722 kg (6,000 lbs)
SCR-550	3051 L (806 G)	435 L/h (115 G/h)		5080 mm (16' 8")	2083 mm (6' 10")	2667 mm (8' 9")	3629 kg (8,000 lbs)

* "Defined Rate" is defined as 2000 BTU/gal. solvent being distilled at 100 deg. differential between the solvent and the heating media.
Custom sizes available upon request.

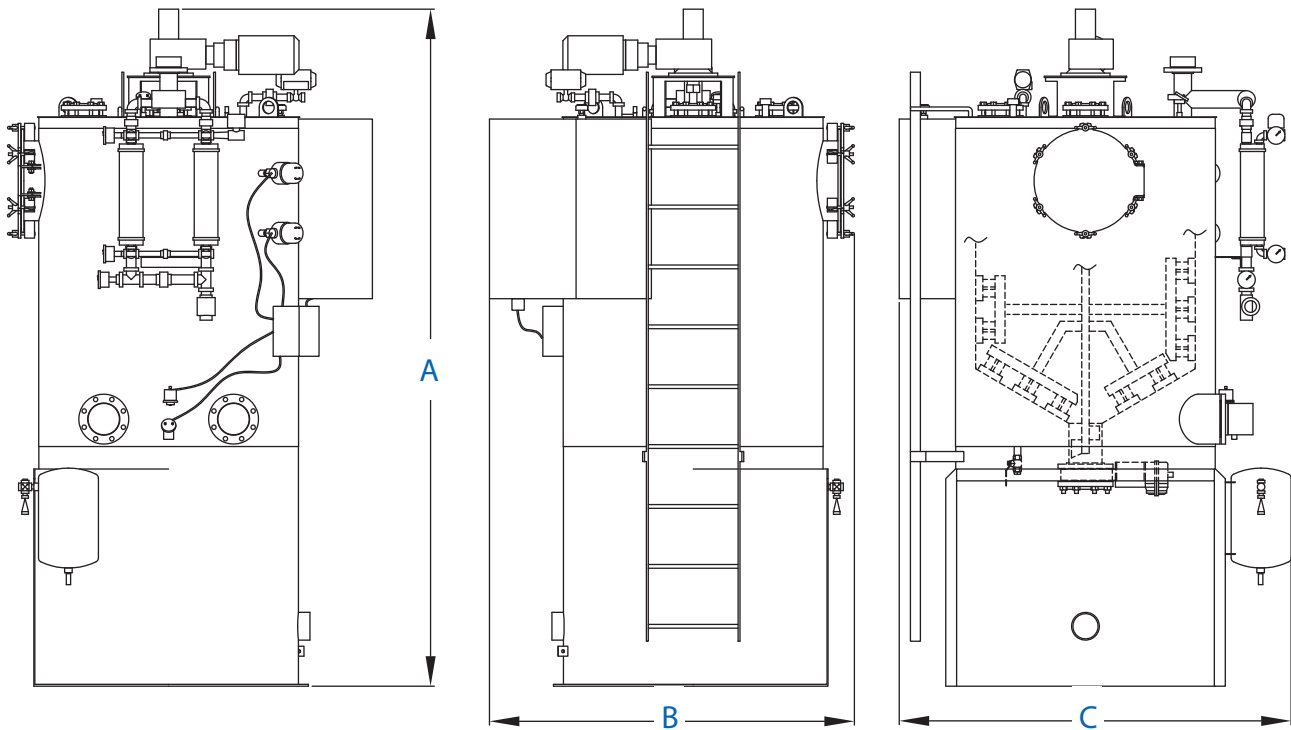

Solvent Wash & Recovery | Biowaste Sterilization | Custom Process Skids | Service

700 Industrial Drive, Dupu IL 62239, (800) 732-3793, www.progressive-recovery.com

SCR-Distillation-Spec-20170309